

Taig Lathe T-Slot

The Taig Micro Lathe II uses #10-32 square nuts for all of its T-SLOTS.

Do NOT use M5 fasteners. The M5 nut has much less bearing area and is too thick for the T-Slot.

This document/file is placed in the **PUBLIC DOMAIN**.
The author assumes no liability for the accuracy, fitness or application of the information or design herein.
Lewis Balentine, Houston, Texas, 9 February 2020

Unless otherwise noted all dimensions are in millimeters [inches]

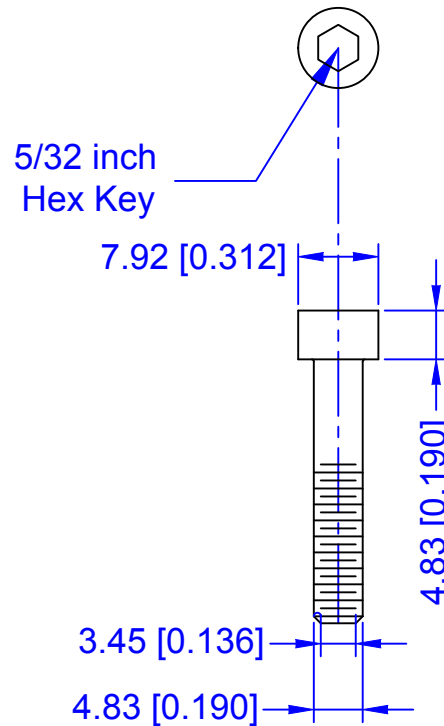

#10-32 Hex Socket Head Cap Screw

Shank X-Section 18 sq mm

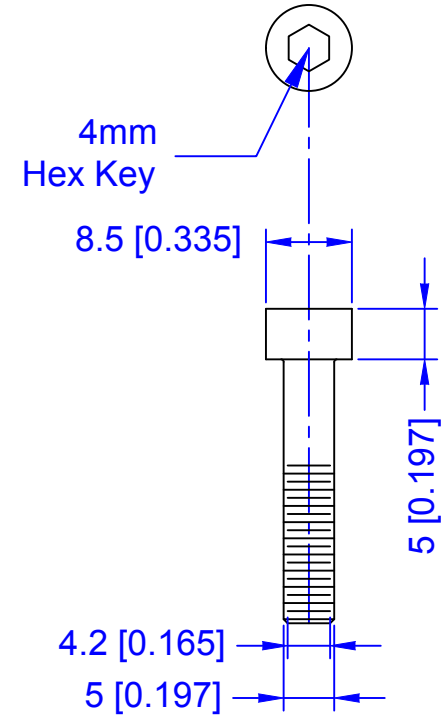

M5x0.8 Hex Socket Head Cap Screw

Shank X-Section 19 sq mm

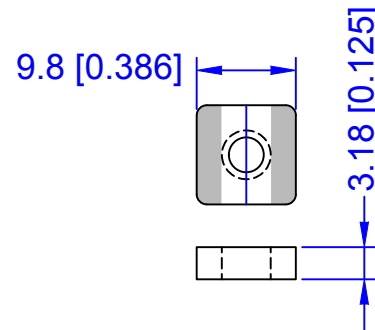

#10-32 Square Nut
Bearing Area 46 sq mm

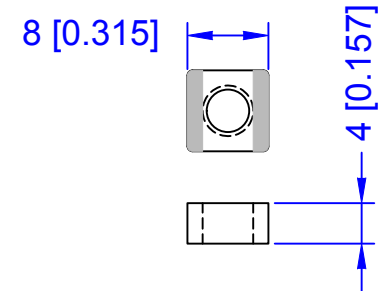

M5x0.8 Square Nut
Bearing Area 24 sq mm